



# FLOMAX<sup>®</sup> 15 316 SS

## 3" X 3" 316 SS Self-Priming Centrifugal Pump

FLOMAX<sup>®</sup> 15, 316 SS self-priming centrifugal pumps are capable of creating vacuum sufficient to lift liquids from heights up to 25 feet above the source. Once primed, the pump's built in flapper valve will maintain a full column of liquid in the suction line.

A FLOMAX<sup>®</sup> 15, 316 SS PumPAK<sup>®</sup> is a fully assembled and run tested pump end that can be easily coupled to a number of drivers such as hydraulic motors, 184TC and 215C frame motors and gas engines. A bearing pedestal is also available for T-frame motor or belt drive.

Standard features include a 3" NPT 150# class flat flange on the suction of the pump, a Viton flapper, a 3" SAE 4-bolt flat face discharge connection, stainless steel drive sleeve, stainless steel fasteners, renewable wear plate, and a semi-open dynamically balanced impeller. Options include a 5-blade stainless steel impeller and seals for all types of abrasive and/or corrosive services.

The FLOMAX<sup>®</sup> series of pumps are commonly used in Industrial, OEM, Agricultural and Marine applications, such as: Bilge Pumps, Auxiliary Fire Pumps, Ballast Transfer Pumps, Washdown Pumps, Fertilizer and Pesticide Pumps, Applicators & Sprayers, Blending Pumps, Nurse Tanks, Bulk Transfer Pumps and much more.



### Application:

- Agricultural
- Industrial
- Marine
- OEM

### Features:

- Renewable wear plate
- Up to 25' suction lift

### Options:

- 5 blade impeller for higher flows
- Available 3" NPT ANSI 150# class discharge flange kit (p/n: 38647)
- Hydraulic motor .73 cu. in.

## SPECIFICATIONS:

Discharge	3" SAE 4-bolt flat face
Suction	3" NPT 150# class flat flange with Viton flapper
Materials of Construction	316 SS
Flow	Up to 300 GPM
Head Feet	Up to 136'
Impeller	6.0" max. diameter, semi-open
Motor	Up to 7.5 HP
Drive Options	Close coupled to 184TC Close coupled to 215C Engine mount to 11HP Engine mount to 13HP Pedestal Pumpak <sup>®</sup> (without motor)
Seal	carbon/ceramic/Viton Special seal material combinations available (consult factory)

CUBIC METERS PER HOUR

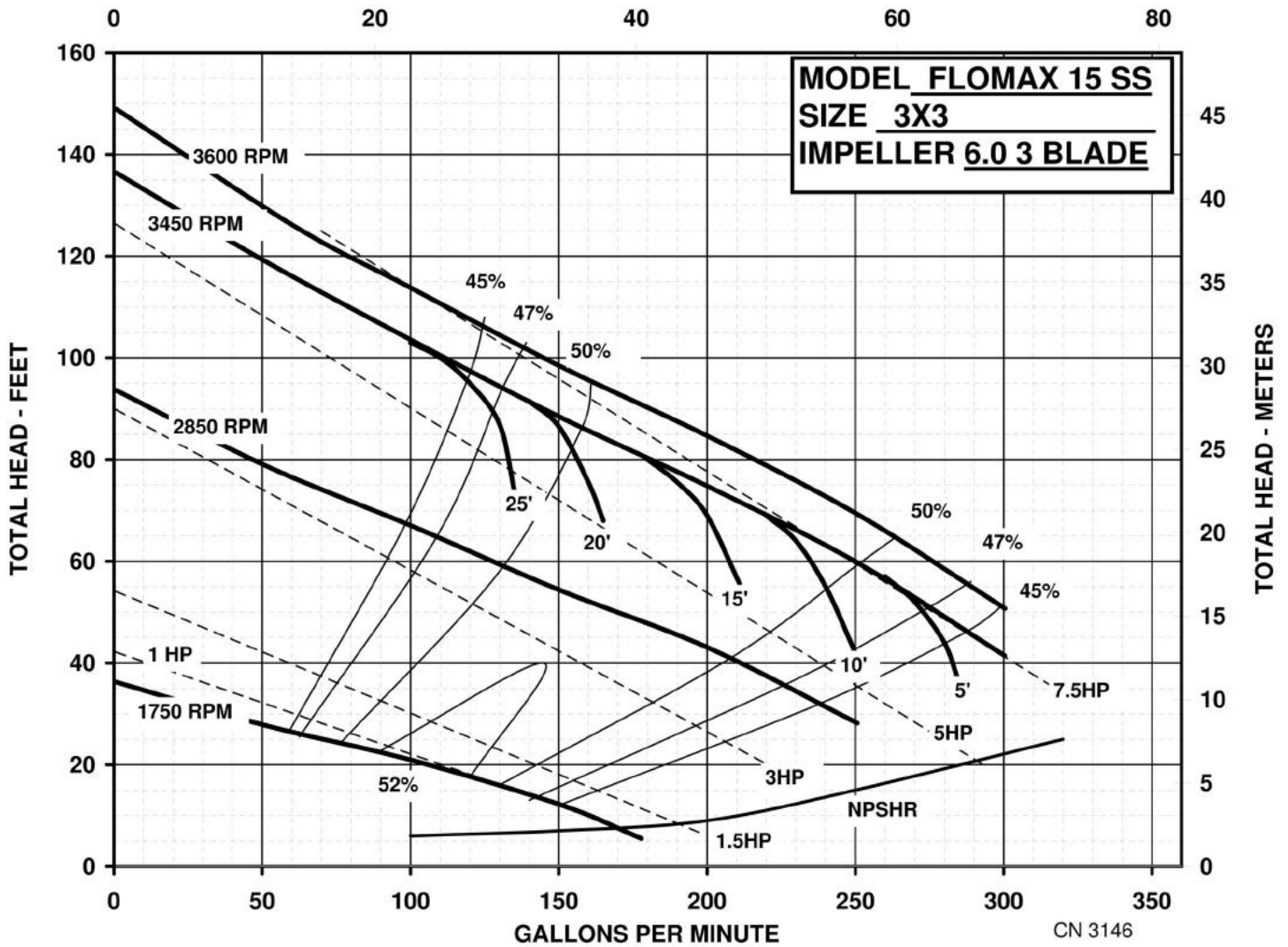

34800 BENNETT • FRASER, MI 48026-1686  
 (586) 293-8240 • FAX (586) 293-8469  
 (800) 563-8006 • www.mppumps.com

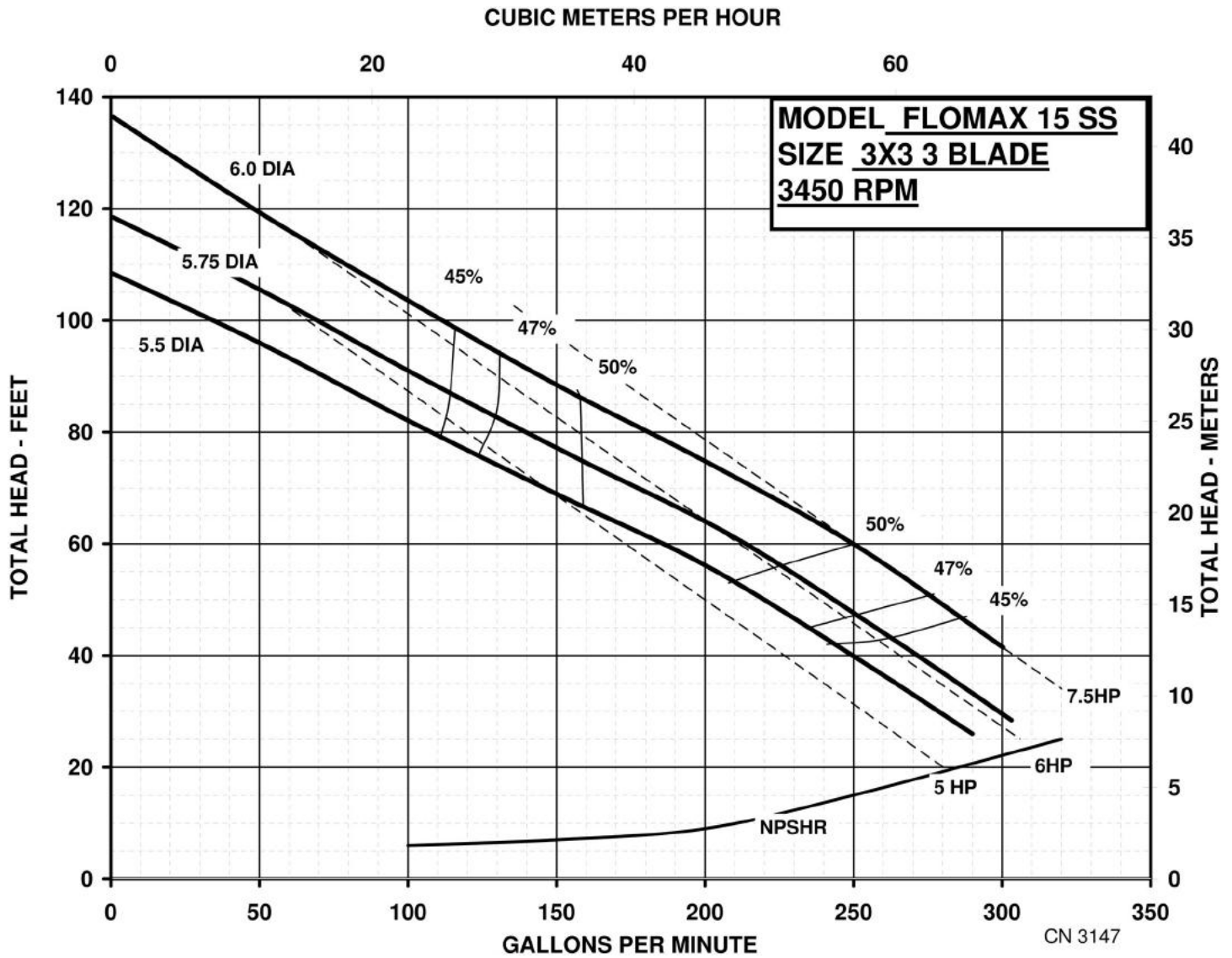

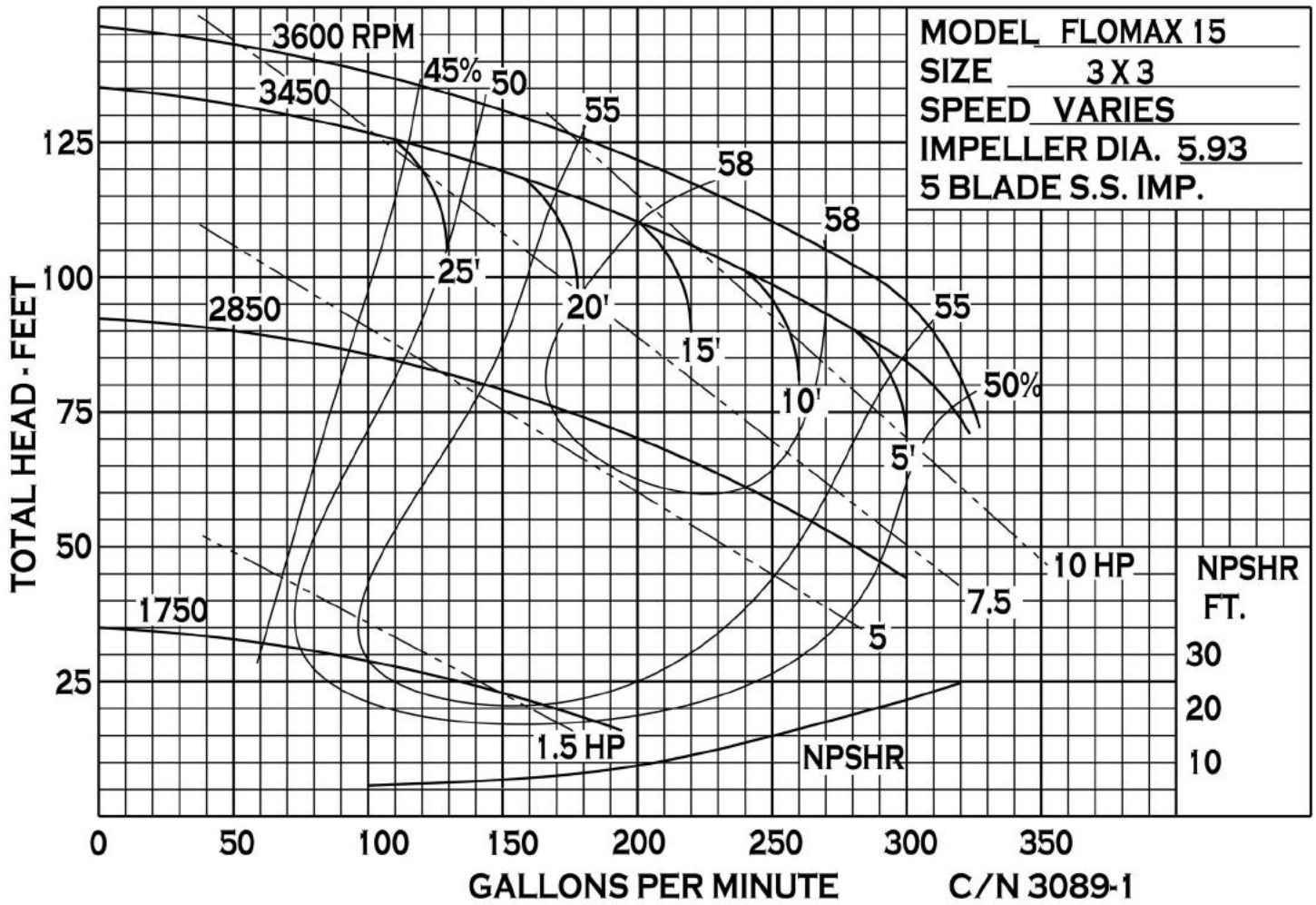

34800 BENNETT • FRASER, MI 48026-1686  
 (586) 293-8240 • FAX (586) 293-8469  
 (800) 563-8006 • www.mppumps.com



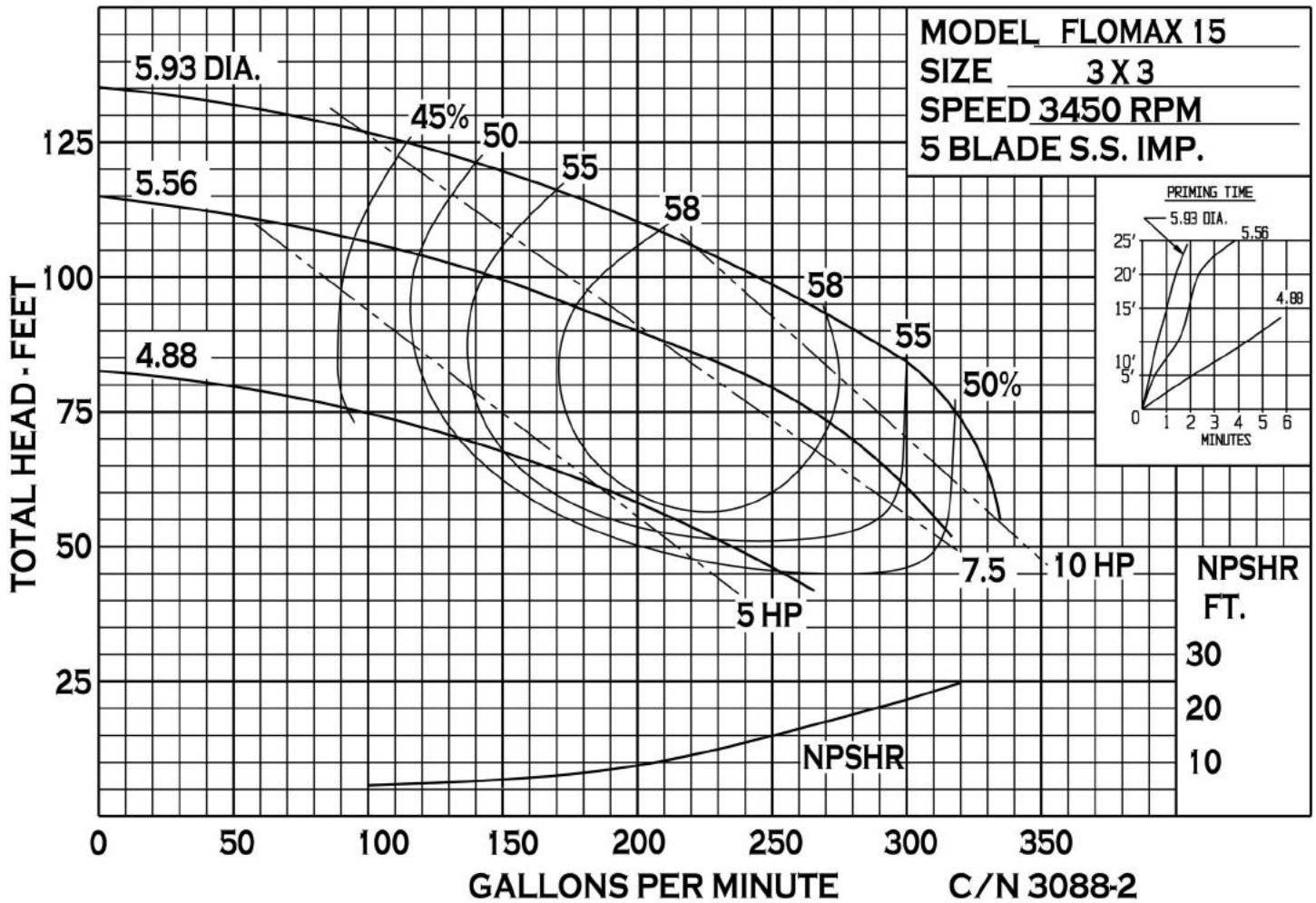

# FLOMAX<sup>®</sup> 15 316 SS

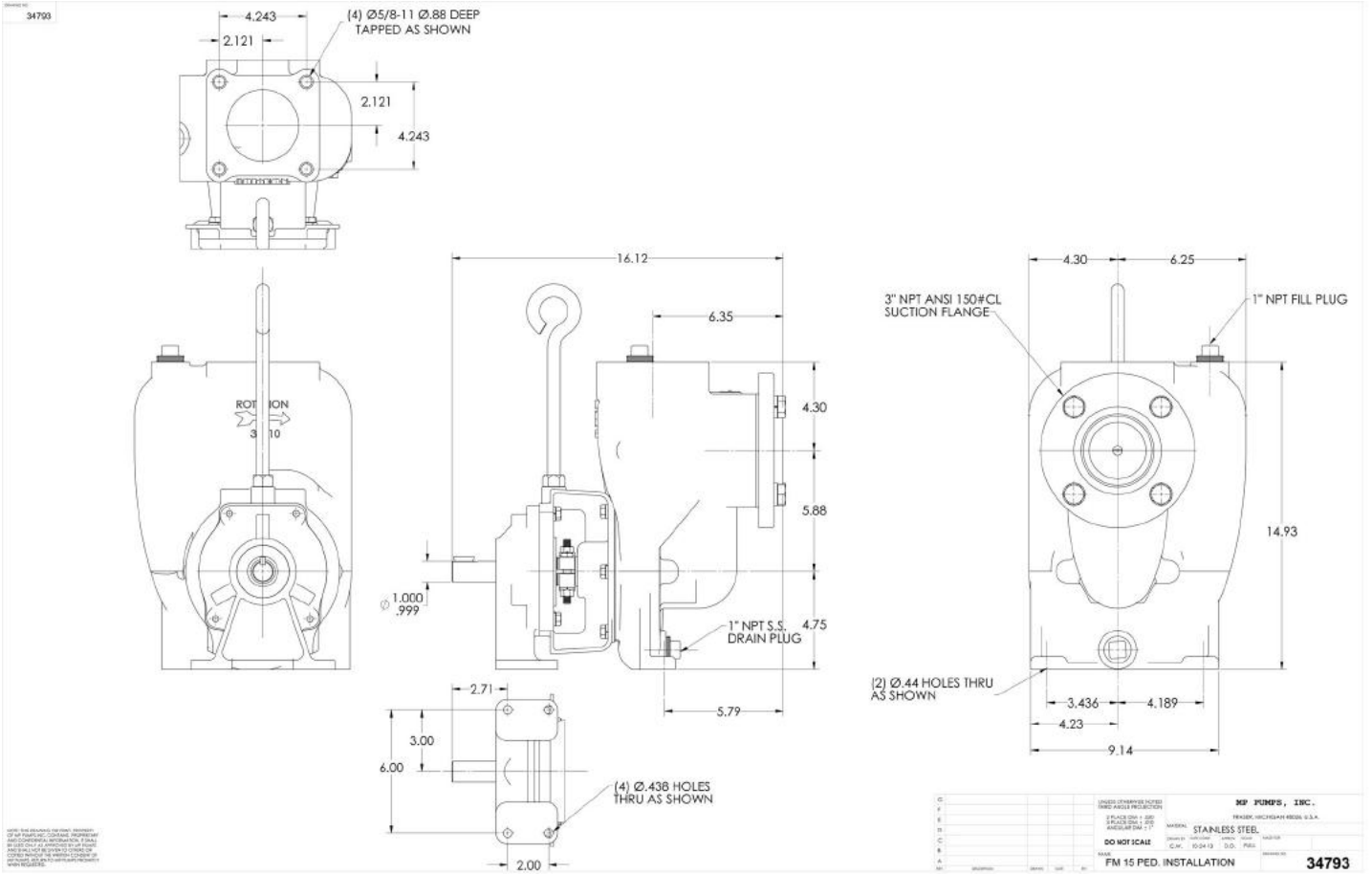

34800 BENNETT • FRASER, MI 48026-1686  
 (586) 293-8240 • FAX (586) 293-8469  
 (800) 563-8006 • www.mppumps.com

# FLOMAX® 15 316 SS

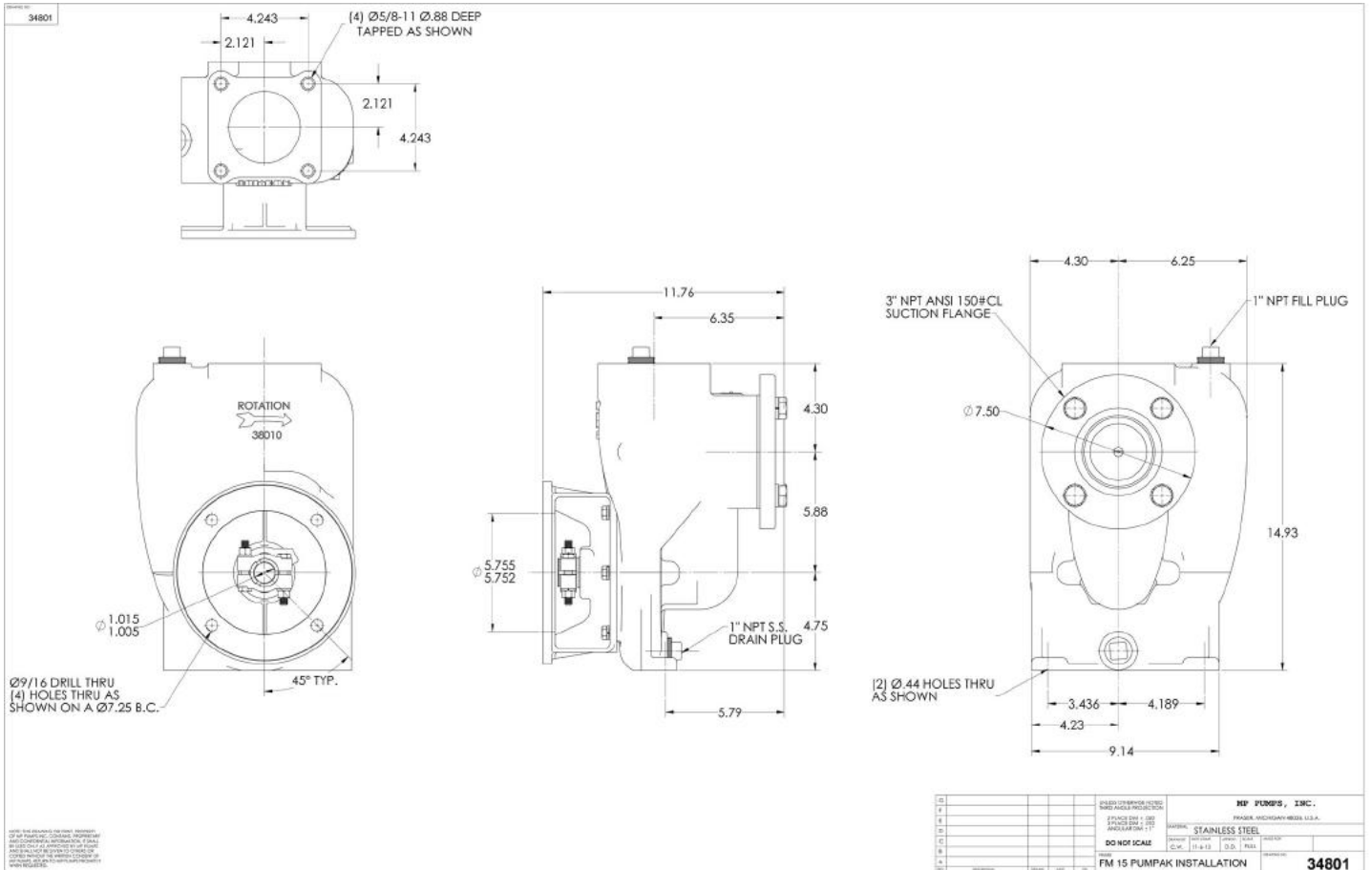

34800 BENNETT • FRASER, MI 48026-1686  
 (586) 293-8240 • FAX (586) 293-8469  
 (800) 563-8006 • www.mppumps.com

# FLOMAX® 15 316 SS

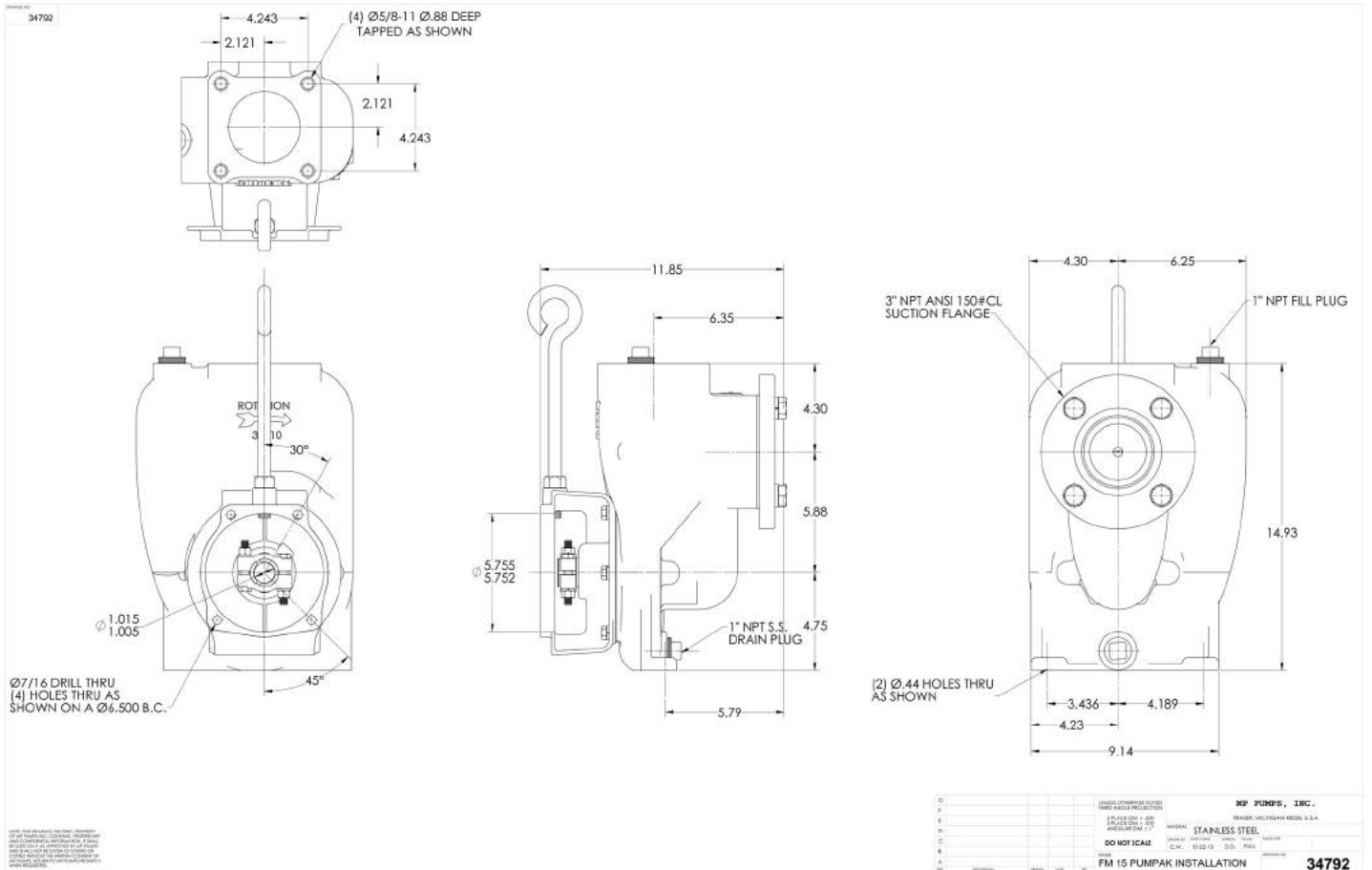

34800 BENNETT • FRASER, MI 48026-1686  
 (586) 293-8240 • FAX (586) 293-8469  
 (800) 563-8006 • www.mppumps.com



34793

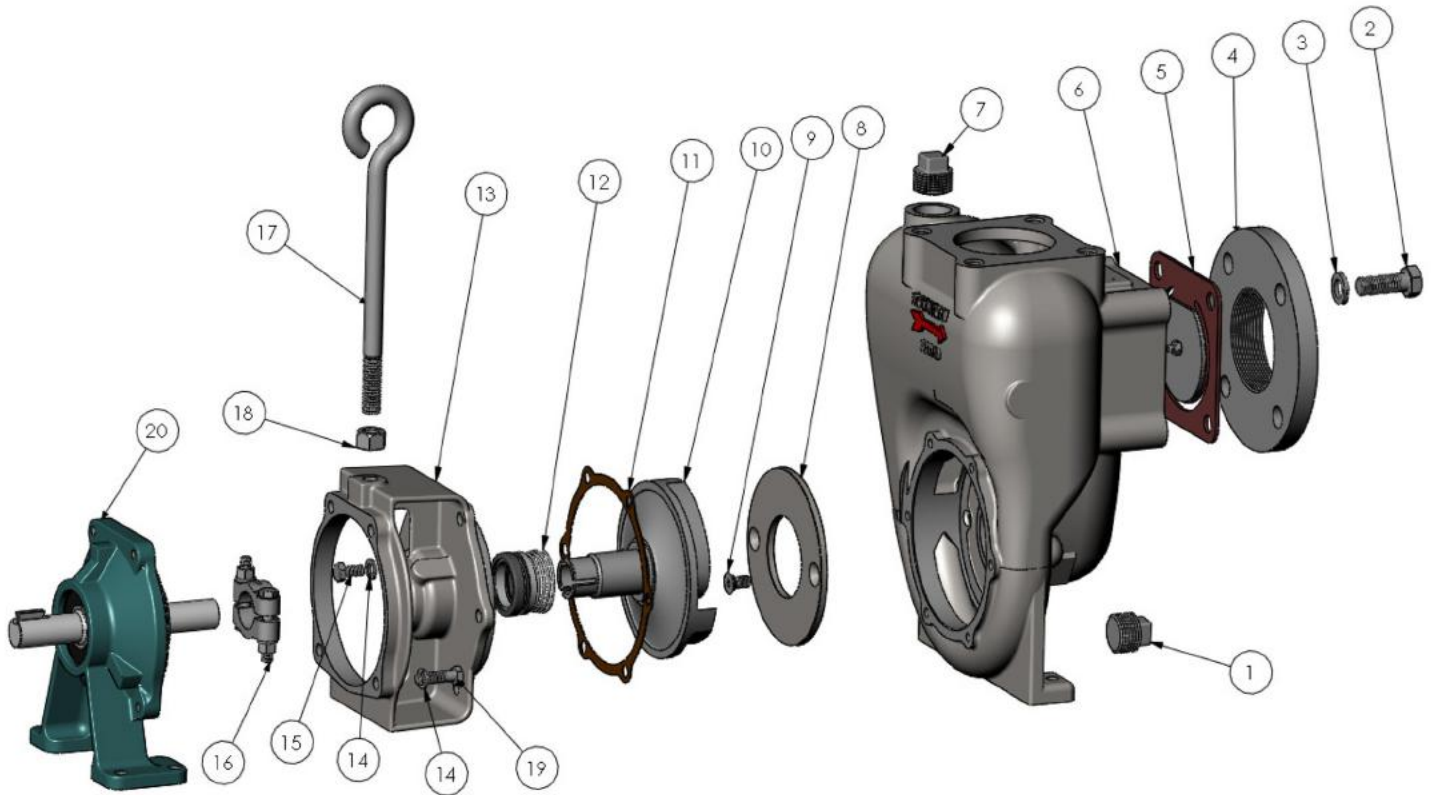

ITEM NO.	PART NO.	DESCRIPTION	QTY.	ITEM NO.	PART NO.	DESCRIPTION	QTY.
1	34780	PIPE PLUG- 1" NPT	1	11	22240	GASKET - NI-2085	1
2	36606	H.H. CAPSCREW S.S. - 5/8-11 X 1.75"	4	12	22361	SEAL ASSY. - 1.5" VITON TYPE 21	1
3	26853	LOCK WASHER S.S. - 5/8	4	13	38038	ADAPTER- S.S.	1
4	38027	FLANGE SUCTION S.S. - 150# CLASS	1	14	21266	LOCK WASHER S.S. - 3/8	12
* 5	38077	FLAPPER ASS'Y - VITON	1	15	25663	H.H. CAPSCREW S.S. - 3/8-16 X .75"	6
6	38011	HOUSING S.S.	1	16	23039	CLAMP ASSY. S.S. - 1"	1
7	34780	PIPE PLUG- 1" NPT	1	17	22460	LIFT EYE ZPS - 5/8-11 X 10"	1
* 8	27979	WEAR PLATE S.S.	1	18	22461	HEX NUT STL. - 5/8-11	1
9	37115	FLAT HD. SCR. S.S. - 3/8-16 X .75"	2	19	21291	H.H. CAPSCREW S.S. - 3/8-16 X .75"	4
10	38070	IMPELLER - 6.0" S.S. 3 BLADE	1	20	26163	PEDESTAL ASSY. C. - LARGE H. DUTY	1

\*- RECOMMENDED REPLACEMENT PARTS



34800 BENNETT • FRASER, MI 48026-1686  
 (586) 293-8240 • FAX (586) 293-8469  
 (800) 563-8006 • www.mppumps.com

## 34801

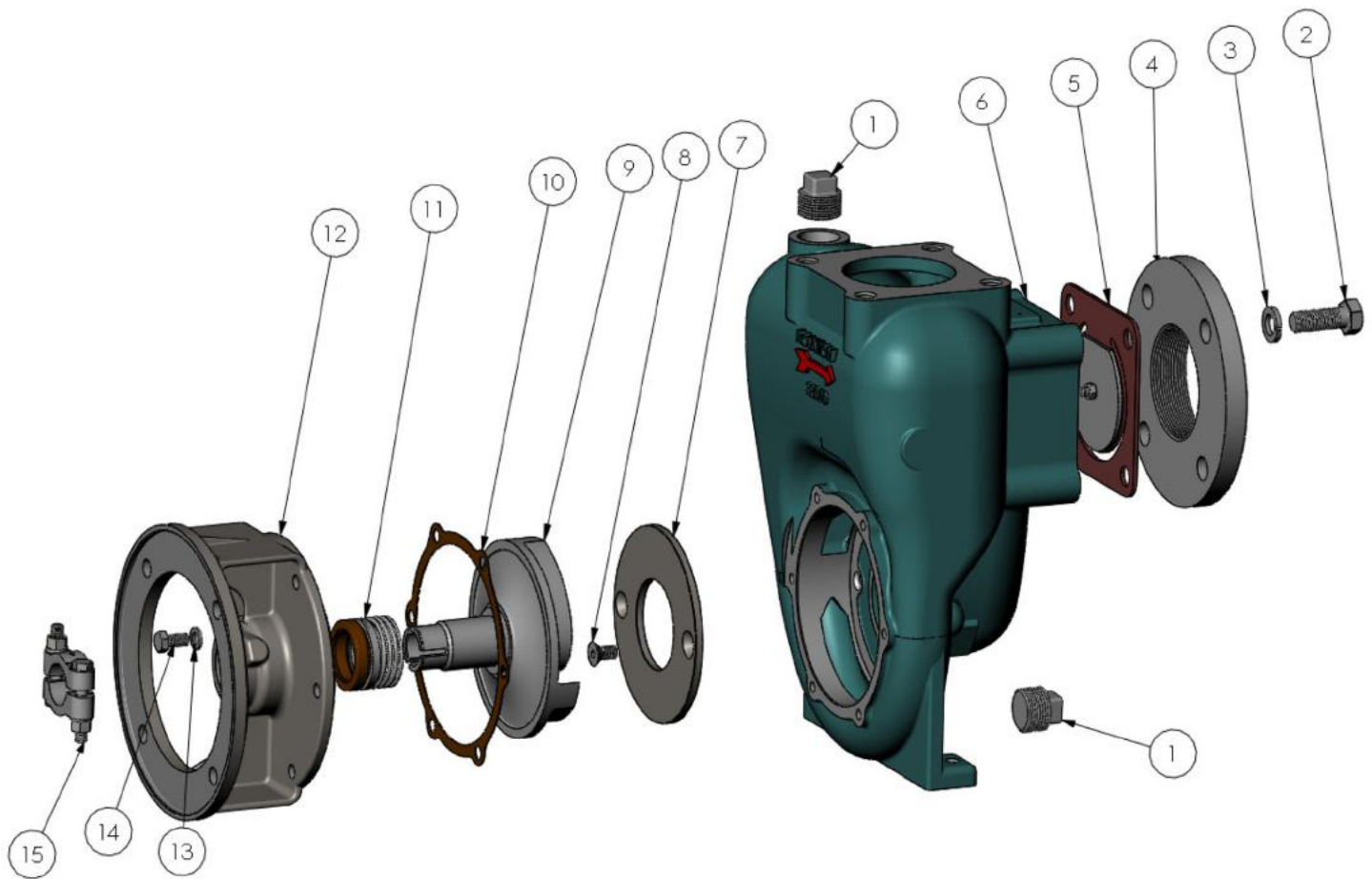

ITEM NO.	PART NO.	DESCRIPTION	QTY.		ITEM NO.	PART NO.	DESCRIPTION	QTY.	
1	34780	PIPE PLUG- 1" NPT	2	*	10	22240	GASKET - NI-2085	1	
2	36806	H.H. CAPSCREW S.S. - 5/8-11 X 1.75"	4	*	11	22361	SEAL ASSY. - 1.5" VITON TYPE 21	1	
3	26853	LOCK WASHER S.S. - 5/8	4		12	38061	ADAPTER- S.S. - CCMTR	1	
4	38027	FLANGE SUCTION S.S. - 150# CLASS	1		13	21266	LOCK WASHER S.S. - 3/8 (4) N/SHOWN	8	
*	5	38077	FLAPPER ASSY - VITON	1		14	21291	H.H. CAPSCREW S.S. - 3/8-16 X 1.12"	10
6	38011	HOUSING S.S.	1		15	23039	CLAMP ASSY. S.S. - 1"	1	
*	7	27979	WEAR PLATE S.S.	1	NOT/SHOWN	21246	H.H. CAPSCREW S.S. - 1/2-13 X 1.25"	4	
8	37115	FLAT HD. SCR. S.S. - 3/8-16 X .75"	2	NOT/SHOWN	21254	LOCK WASHER S.S. - 1/2"	4		
9	38078	IMPELLER - 6.0" S.S. 3 BLADE	1						

\*- RECOMMENDED REPLACEMENT PARTS



34800 BENNETT • FRASER, MI 48026-1686  
 (586) 293-8240 • FAX (586) 293-8469  
 (800) 563-8006 • www.mppumps.com

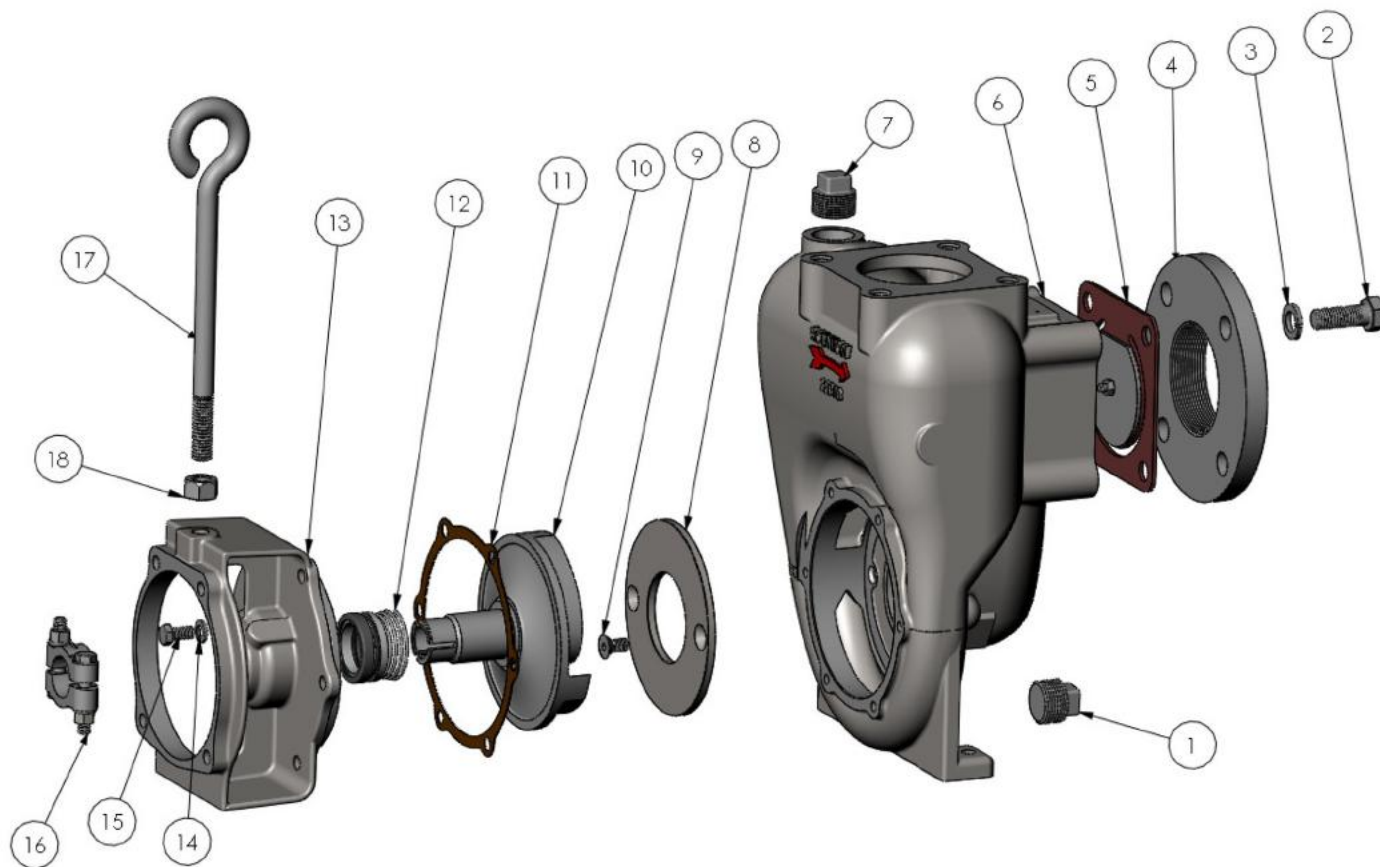

ITEM NO.	PART NO.	DESCRIPTION	QTY.	ITEM NO.	PART NO.	DESCRIPTION	QTY.
1	34780	PIPE PLUG- 1" NPT	1	* 11	22240	GASKET - NI-2085	1
2	36606	H.H. CAPSCREW S.S. - 5/8-11 X 1.75"	4	* 12	22361	SEAL ASSY. - 1.5" VITON TYPE 21	1
3	26853	LOCK WASHER S.S. - 5/8	4	13	38038	ADAPTER- S.S.	1
4	38027	FLANGE SUCTION S.S. - 150# CLASS	1	14	21266	LOCK WASHER S.S. - 3/8 (4) N/SHOWN	16
* 5	38077	FLAPPER ASS'Y - VITON	1	15	25663	H.H. CAPSCREW S.S. - 3/8-16 X .75"	6
* 6	38011	HOUSING S.S.	1	16	23039	CLAMP ASSY. S.S. - 1"	1
7	34780	PIPE PLUG- 1" NPT	1	17	22460	LIFT EYE ZPS - 5/8-11 X 10"	1
* 8	27979	WEAR PLATE S.S.	1	18	22461	HEX NUT STL. - 5/8-11	1
9	37115	FLAT HD. SCR. S.S. - 3/8-16 X .75"	2	19	21291	H.H. CAPSCREW S.S. - 3/8-16 X .75"	4
10	38070	IMPELLER - 6.0" S.S. 3 BLADE	1			(4) ABOVE NOT SHOWN PACKED LOOSE.	

\*- RECOMMENDED REPLACEMENT PARTS



34800 BENNETT • FRASER, MI 48026-1686  
 (586) 293-8240 • FAX (586) 293-8469  
 (800) 563-8006 • www.mppumps.com