



Now available with an optional higher base.

# GT IRRI-GATOR™

SELF-PRIMING® CENTRIFUGAL PUMPS - 60 HZ

### FEATURES

① **Self-Priming Design:** Once pump is initially primed, filled with water, it will reprime when the water level rises above the end of the suction pipe.

#### Serviceable:

- Back pullout design allows disassembly of pump for service without disturbing piping.
- Two compartment motor for easy access to motor wiring and replaceable components.

**Diffuser (Guidevane):** Bolt down diffuser provides positive alignment with impeller. F.D.A. compliant, injection molded, glass filled Lexan® for durability and abrasion resistance.

**Impeller:** F.D.A. compliant, glass filled Noryl®. Corrosion and abrasion resistant.

**Corrosion Resistant:** Electro-coat paint process is applied inside and out, then baked on.

**Casing:** Cast iron, 4-bolt, back pull-out design. Openings for vacuum gauge and casing drain.

**Powered for Continuous Operation:** Pump ratings are within the motor manufacturer's recommended working limits. Can be operated continuously without damage.

**Mechanical Seal:** Carbon/ceramic faces, BUNA elastomers. 300 series stainless steel metal parts. Diaphragm prevents the seal from running dry.

### APPLICATIONS

Specifically designed for the following uses:

- Lawn sprinkling
- Irrigation
- Air conditioning systems
- Heat pumps
- Water transfer
- Dewatering

### SPECIFICATIONS

#### Pump:

- Pipe connections:  
1½" NPT suction  
1½" NPT discharge
- Capacities: to 110 GPM at 5 foot suction lift
- Heads: to 128 feet
- Reprime capabilities: to 25 feet suction lift
- Maximum water temperature: 140° F (60° C)
- Rotation: clockwise when viewed from motor end.

#### Motor:

- NEMA standard open drip proof
- 60 Hz, 3500 RPM
- Stainless steel shaft
- Single phase: ¾-1½ HP, 115/230 V; 2 and 3 HP, 230 V only. Built-in overload with automatic reset.
- Three phase: 230/460 V. Overload protection must be provided in starter unit. Starter and heaters (3) must be ordered separately.
- Optional TEFC motors are available. See price book for order numbers.



GT -- S with optional base

### AGENCY LISTINGS



Canadian Standards Association



Tested to UL778 (except GT30\_)



Class 6853 01 - Low Lead Content Certification

### STANDARD ODP MODELS

Model	HP	Phase
GT07	¾	1
GT10	1	
GT15	1½	
GT20	2	
GT30	3	3
GT073	¾	
GT103	1	
GT153	1½	
GT203	2	
GT303	3	

Add on "S" suffix for extended base. See back page.

### PERFORMANCE CURVE

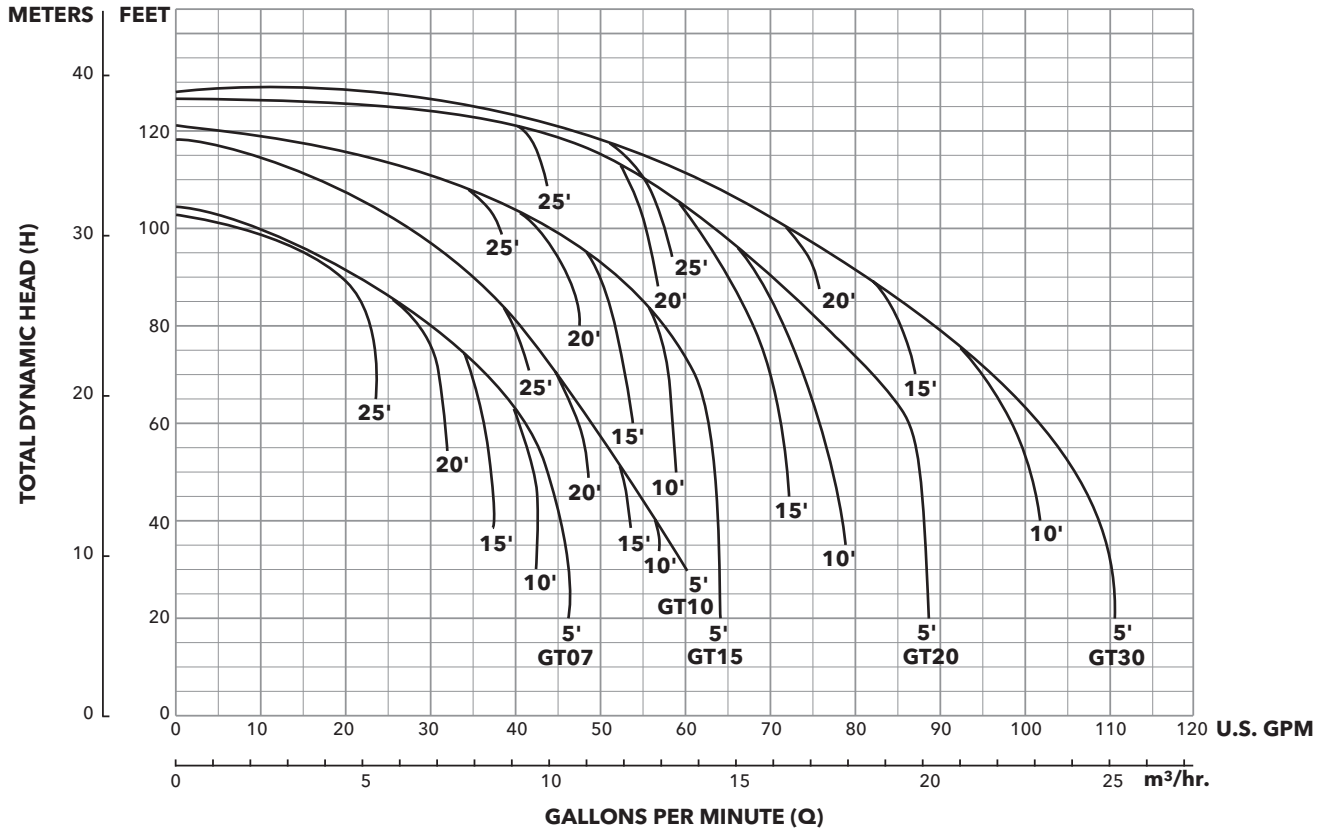

Single and three phase have same performance.

### PERFORMANCE RATINGS

Model	PSI Discharge Pressure	Suction Lift in Feet				
		5	10	15	20	25
GT07/ GT073	20	44	41	36	31	24
	30	34	31	26	22	14
	40	10	4	0	0	0
GT10/ GT103	20	53	51	49	46	41
	30	43	41	38	36	32
	40	29	22	16	8	0
GT15/ GT153	20	63	59	54	49	39
	30	60	55	51	46	37
	40	45	38	33	20	14
GT20/ GT203	20	86	77	70	59	46
	30	80	72	67	57	44
	40	65	60	57	50	43
GT30/ GT303	20	105	100	88	76	60
	30	92	90	84	75	57
	40	73	67	62	55	50

Performance ratings are in GPM.

### SELF-PRIMING (AFTER INITIAL PRIME)<sup>®</sup>

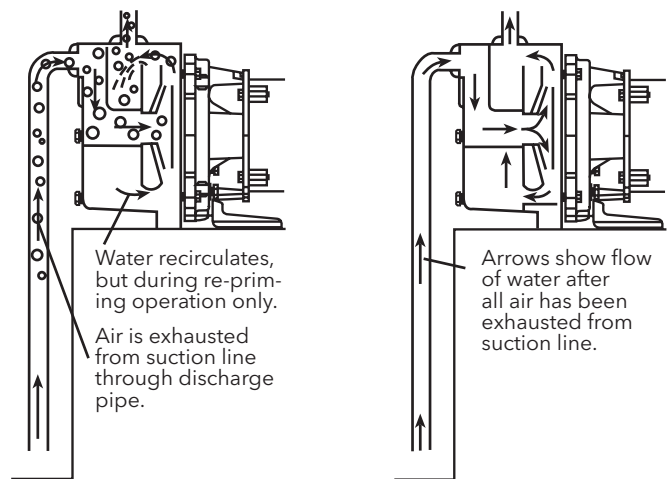

## COMPONENTS

Item No.	Description
1	Plug - ¼" NPT
2	Casing
3	Seal ring - diffuser
4	Diaphragm
5	Machine screw
6	Diffuser with SS wear ring
7	Impeller
8	Mechanical seal
9A	Foot - ¾ and 1 HP
9B	Base - 1½ HP and up
9C	Extended base - "S" suffix ①
10	Bolt - foot to adapter
11	Motor adapter
12	Bolt - casing to adapter
13	Bolt - adapter to motor
14	Deflector

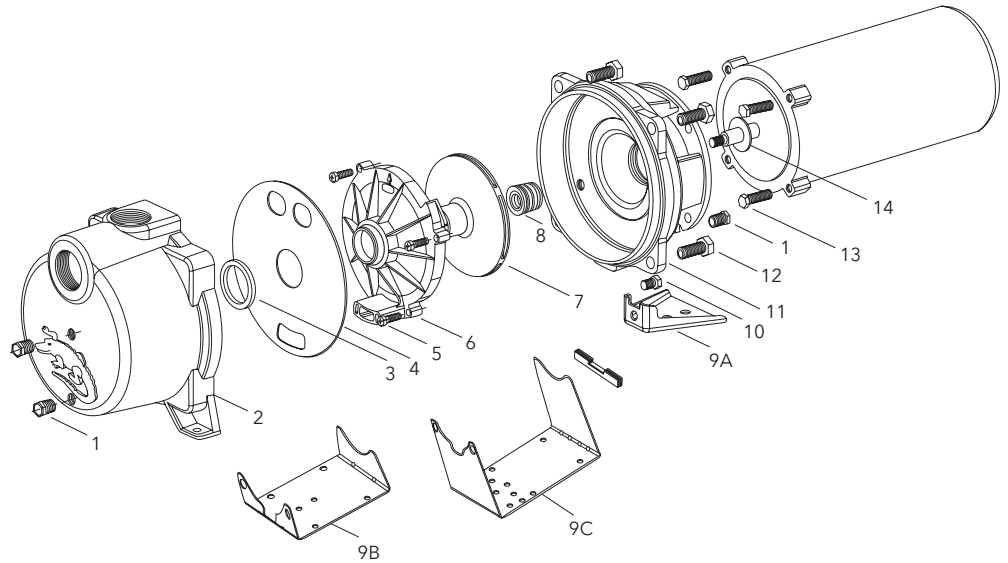

① 9C - Order by adding an "S" suffix, ex. GT07S.  
It is also sold as a 15K86 stand alone part.

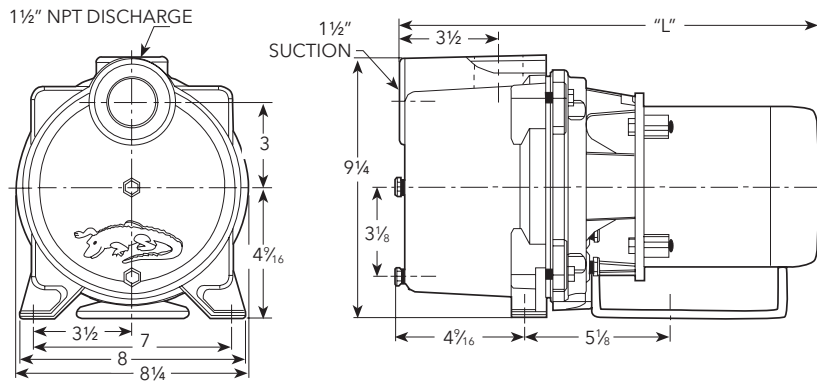

## DIMENSIONS AND WEIGHTS

Model	GT07	GT10	GT15	GT20	GT30	GT073	GT103	GT153	GT203	GT303
HP	¾	1	1½	2	3	¾	1	1½	2	3
Length "L"	19 3/16	19 7/8	21 3/16	20 31/32	21 11/32	19	19 3/4	20 1/16	20 13/16	21 3/16
Width	8 1/4									
Height	9 1/4 (13 1/4 with "S" Base)									
Weight (lbs.)	48	52	60	65	76	49	52	55	69	71
Phase	Single					Three				

(All dimensions are in inches and weights in lbs. Do not use for construction purposes.)

**xylem**  
Let's Solve Water

Xylem Inc.  
2881 East Bayard Street Ext., Suite A  
Seneca Falls, NY 13148  
Phone: (866) 325-4210  
Fax: (888) 322-5877  
www.gouldswatertechnology.com

Goulds is a registered trademark of Goulds Pumps, Inc. and is used under license. Irri-gator is a trademark of Xylem Inc. or one of its subsidiaries. Noryl and Lexan are registered trademarks of GE Plastic.  
© 2012 Xylem Inc. BGT R1 December 2013