



FEATURES

High Capacity and Pressure: Specifically designed to deliver high capacities at deeper settings.

Stainless Steel Pump Shaft: Hex design provides positive drive for impellers and eliminates clearance adjustments.

Easy to Service: Can be taken apart for service by removing four bolts.

Corrosion Resistant: Glass filled thermoplastic impellers. Stainless steel wear rings and coverplates. Electrocoat paint process applied inside and out and then baked on.

Powered for Continuous Operation: Pump is designed for continuous operation. All ratings are within the motor manufacturer's recommended working limits.

Easy to Prime: Top mounted vent plug allows air to escape from seal cavity during initial priming.

Adjustable Automatic Pressure Control Valve: Guarantees maximum capacity at all times. By-pass check valve equalizes pressure in entire system and helps prevent loss of prime.

SJ

60 HZ VERTICAL JET PUMPS DEEP WELL

PERFORMANCE RATINGS – TWIN PIPE SYSTEMS

HP/Model	¾ HP - SJ07			1 HP - SJ10			1½ HP - SJ15			2 HP - SJ20			
Well Casing Min. I.D. in.	4												
Pressure	1												
Suction Pipe Size (in.)	1¼												
Jet Assembly Package ①	FT4-48	FT4-47	FT4-06	FT4-47	FT4-24	FT4-08	FT4-45	FT4-30	FT4-29	FT4-45	FT4-30	FT4-29	
Jet Body (Only)	AT4												
Nozzle	AN012	AN013	AN014	AN013	AN015			AN013					
Venturi	AD727	AD724	AD720	AD724		AD720	AD726	AD722	AD719	AD726	AD722	AD719	
Control Valve Setting (PSI) ②	37	40			43		62	65	67	76	78	80	
Depth to Jet Assembly (based on submergence of 5 feet)	Feet	Gallons Per Minute (GPM) 30-50 Pressure Switch Setting											
	30	15.2			16.0			13.0			13.0		
	40	13.5			15.2			13.0			13.0		
	50	11.8			14.7			13.0			13.0		
	60	10.7			13.7			12.8			12.8		
	70	8.5	9.0		11.7	11.7		12.2			12.8		
	80		7.5			10.5		10.6			12.0		
	90		6.2	6.2		9.0		9.2	9.3		11.3		
	100			5.8		7.5			9.0		9.5	9.5	
	110			5.0		6.3	6.0			8.0			9.4
	120			4.6			5.0			7.0			8.5
	130			4.0			4.3			6.2	5.8		7.7
	140						4.0				5.6		6.8
	150						3.5			5.2		6.0	5.7
	160									4.7			5.5
	170									4.2			5.3
	180									3.7			5.0
190									3.2			4.7	
200												3.8	

NOTE: An offset of 50 feet will result in a decrease of about 25% from ratings as shown.

① Jet assembly package includes jet body (AT4), venturi, nozzle and foot valve.

② Deep well jet pumps require a pressure control device on the discharge to provide back pressure to the jet assembly. Failure to control the amount of discharge by adjusting the back pressure (pressure control valve setting) will cause the pump to lose prime. On pumps with low control valve settings, up to 40 psi, a simple ball valve or AV15 will work. On systems with control valve settings of 40 - 80 psi an AV22, AV22KIT or AV21 is required. They measure the pressure on the outbound side so that the high pressure does not open the 30-50 psi switch and turn the pump off.

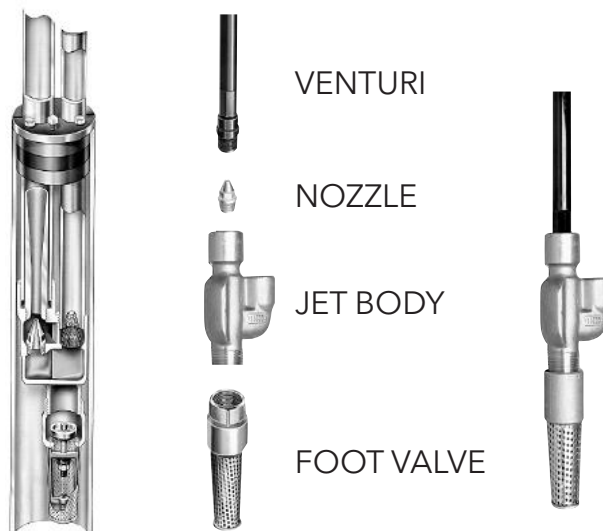

PERFORMANCE RATINGS – PACKER SYSTEM

HP/Model	¾ HP SJ07					1 HP SJ10					1½ HP SJ15					2 HP SJ20							
Well Casing In.	2		3			2		3			2		3			2		3					
Suction Pipe Size (in.)	1¼		1½			1¼		1½			1¼		1½			1¼		1½					
Jet Assembly Package ①	FP2-51	FP2-50	FP2-06	FP3-40	FP3-42	FP2-50	FP2-07	FP2-08	FP3-40	FP3-49	FP2-49	FP2-30	FP2-29	FP3-47	FP3-46	FP3-34	FP2-49	FP2-30	FP2-29	FP3-47	FP3-46	FP3-34	
Jet Body (Only)	AP2		AP3			AP2		AP3			AP2		AP3			AP2		AP3					
Nozzle	AN012	AN013	AN014	AN013	AN014	AN013	AN014	AN015	AN013	AN015	AN013												
Venturi	AD727	AD724	AD720	AD724	AD722	AD724	AD720	AD724	AD723	AD726	AD722	AD719	AD727	AD722	AD719	AD726	AD722	AD719	AD727	AD722	AD719		
Pressure ② Control Valve Setting (PSI)	40		36	40		45		40	43	62	65	67	62	64	66	76	78	80	75	78	80		
Depth to Jet Assembly (based on submergence of 5 feet)	Feet	Gallons Per Minute 30-50 Pressure Switch Setting																					
	30	14.9			15.3		15.8			16.3		13.0			14.7			13.0			14.7		
	40	13.1			13.5		14.0			16.0		13.0			14.5			13.0			14.7		
	50	11.6			12.5		12.5			15.5		12.9			14.3			13.0			14.7		
	60	10.5			12.2		11.2	11.3		14.2		12.7			14.3			13.0			14.5		
	70	8.4	8.8		11.8			10.0		12.5		11.8			14.2			12.8			14.5		
	80		7.6		10.2	8.5		8.7		10.0		10.2			12.2			11.8			13.5		
	90		6.1	6.2		7.8		7.3		8.3	9.0	8.3	9.1		10.0			10.5			12.7		
	100			5.7		6.9		5.5			8.2		8.3		7.8	9.1		8.5	9.1		10.5		
	110			4.3		6.0		4.2	4.8		7.3		7.3			8.8			8.9		8.3	9.1	
	120			3.8		5.3			4.0		6.7		6.2			7.6			7.9			9.1	
	130			2.2		4.5			3.5		5.8		5.4	5.6		6.9			6.9			8.8	
	140								3.0		4.8			5.3		6.2			6.0			8.2	
	150								2.4		4.1				4.8	5.4	5.6		5.2	5.6		7.3	
	160														4.3			5.5			5.4	6.5	
	170																	5.0			4.9	5.7	5.7
	180																	4.7			4.3		5.6
	190																	4.3			3.8		5.5
	200																	3.8			3.3		5.3
	210																	3.3					4.8
220																						4.5	
230																						4.0	

NOTE: An offset of 50 feet will result in a decrease of about 25% from ratings as shown. Special turned (diameter) couplings are required on 2" packer systems, order no. 64655 in Jet and Sub price book.

- ① Jet Assembly Package includes jet body, AP2 or AP3; built-in check valve, nozzle and venturi.
- ② Deep well jet pumps require a pressure control device on the discharge to provide back pressure to the jet assembly. Failure to control the amount of discharge by adjusting the back pressure (pressure control valve setting) will cause the pump to lose prime. On pumps with low control valve settings, up to 40 psi, a simple ball valve or AV15 will work. On systems with control valve settings of 40 - 80 psi an AV22, AV22KIT or AV21 is required. They measure the pressure on the outbound side so that the high pressure does not open the 30-50 psi switch and turn the pump off.



COMPONENTS

Item No.	Description
1	Mechanical seal
2	Corrosion resistant impellers
3	Pressure switch
4	Pressure control valve
5	Rugged cast iron construction
6	Electro-coat paint
7	Stainless steel hex shaft
8	Stainless steel wear rings
9	Stainless steel cover plates
10	O-ring seals

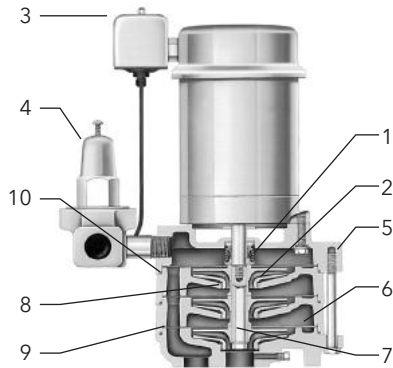

AGENCY LISTINGS

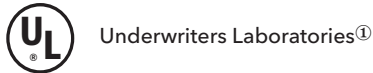

DIMENSIONS AND WEIGHTS

HP/Model	¾-SJ07	1-SJ10	1½-SJ15	2-SJ20
Stages	2	2	3	3
Weight	58	63	77	88
Length	14	14	14	14
Width	8	8	8	8
Height	15½	16	20	20½

Pressure Control Valve included in dimensions.

(All dimensions are in inches and weight in lbs. Do not use for construction purposes.)

APPLICATIONS

Specifically designed for:

- Homes
- Farms
- Cottages

SPECIFICATIONS

Pipe connection –
 1" NPT drive (pressure)
 1¼" NPT suction
 1" NPT discharge

Pressure switch –
 ¾-1½ HP, AS4
 2 HP, AS10
 both preset (30-50 PSI)

- NEMA standard
- ¾-1½ HP, 115/230 V, 60 Hz, capacitor start
- 2 HP, 230 V only, 60 Hz
- Single phase
- 3500 RPM
- Built-in overload with automatic reset
- Stainless steel shaft
- Rotation: clockwise when viewed from motor end.

140° F

REQUIRED SYSTEM COMPONENTS

- **Basic Pump Unit:** Includes pump, motor, pressure switch, tubing, fittings, pressure gauge, bushing and AV21 pressure control valve.
- **Deep Well Jet Assembly Package:** Twin Pipe includes: Jet body, nozzle, venturi and foot valve. Packer includes: Jet body with built-in check valve, nozzle and venturi.
- **Additional Accessories Required:** For Packer: well casing adapter AWD2 (2") or AWD3 (3").

MODEL SJ

For twin pipe or packer systems.



MODEL INFORMATION

CSA Listed Order No.	U.L. Listed (Indoor use) ① Order No.	HP	Stages
SJ07	SJ07UL	¾	2
SJ10	SJ10UL	1	2
SJ15	SJ15UL	1½	3
SJ20	SJ20UL	2	3

xylem
Let's Solve Water

Xylem, Inc.
 2881 East Bayard Street Ext., Suite A
 Seneca Falls, NY 13148
 Phone: (866) 325-4210
 Fax: (888) 322-5877
www.xylem.com/brands/gouldswatertechnology

Goulds is a registered trademark of Goulds Pumps, Inc. and is used under license.
 © 2012 Xylem Inc. BSJ March 2012